

## Select The Right Operational Amplifier For Your Filtering Circuits

By Bonnie C. Baker, Microchip Technology Inc.

Analog filters can be found in almost every electronic circuit. Audio systems use them for pre-amplification and equalization. In communication systems, filters are used for tuning specific frequencies and eliminating others. But if an analog signal is digitized, low-pass filters are always used to prevent aliasing errors from out-of-band noise and interference.

Analog filtering can remove higher frequency noise superimposed on the analog signal before it reaches the analog-to-digital converter. In particular, this includes low-level noise, as well as extraneous noise peaks. Any signal that enters the analog-to-digital converter is digitized. If the signal is beyond half of the sampling frequency of the converter, the magnitude of that signal is converted reliably, but the frequency is modified as it aliases back into the digital output. You can use a digital filter to reduce the noise after digitizing the signal, but keep in mind the rule of thumb: "Garbage in will give you garbage out".

The task of selecting the correct single supply operational amplifier (op amp) for an active low-pass filter circuit can appear overwhelming, as you read any op amp data sheet and view all of the specifications. For instance, the number of DC and AC Electrical Specifications in Microchip's 5 MHz, single supply, **MCP6281/2/3/4** data sheet is twenty-four. But in reality, there are only two important specifications that you should initially consider when selecting an op amp for your active, low-pass filter. Once you have chosen your amplifier, based on these two specifications, there are two additional

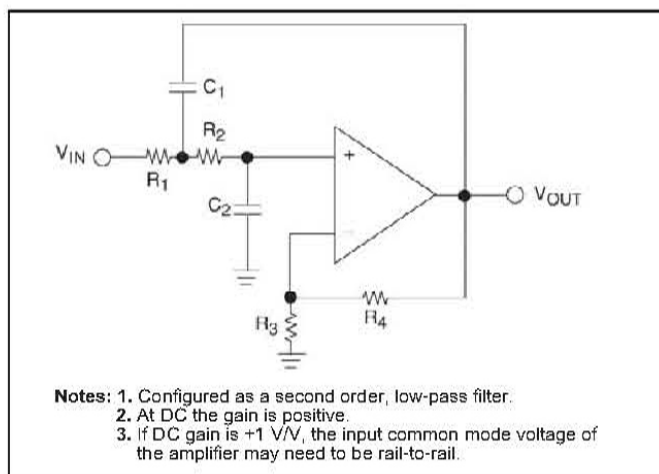

Figure 1: Second Order, Sallen-Key, Low-pass Filter.

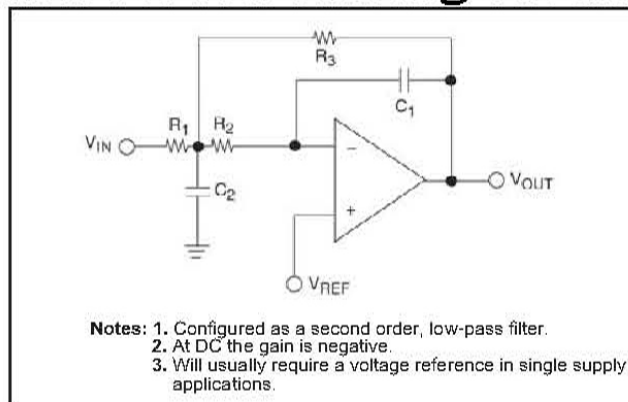

Figure 2: Second Order, Multiple Feedback, Low-pass Filter.

specifications that you should consider before reaching your final decision. The most common topologies for second order, active low-pass filters are shown in Figure 1 and Figure 2.

In Figure 1, the non-inverting Sallen-Key is designed so that the input signal is not inverted. A gain option is implemented with R3 and R4. If you want a DC gain of +1 V/V, R3 should be removed and R4 should be shorted. A second order, multiple feedback configuration is shown in Figure 2. With this circuit topology, the input signal is inverted around the reference voltage, VREF. If a higher order filter is needed, both of these topologies can be cascaded.

The two key specifications that you should initially consider when designing with either of these topologies is Gain Bandwidth Product (GBWP) and slew rate. Prior to the selection of the op amp, you need to determine the filter cutoff frequency ( $f_c$ ), also known as the frequency where your filter starts to attenuate the signal. Sometimes, in literature, you will find that this is called the pass band frequency. Once this is done, the FilterLab® filter design software program (available at [www.microchip.com](http://www.microchip.com)) can be used to determine the capacitor and resistor values.

Since you have already defined your cutoff frequency, selecting an amplifier with the right bandwidth is easy. The closed-loop bandwidth of the amplifier must be at least 100 times higher than the cutoff frequency of the filter. If you are using the Sallen-Key configuration and your filter gain is +1 V/V, the GBWP of your amplifier should be equal to or greater than 100  $f_c$ . If your closed loop gain is larger than +1 V/V, your GBWP should be

equal to or greater than 100  $G_{CLN}f_c$ , where  $G_{CLN}$  is equal to the non-inverting closed-loop gain of your filter. If you are using the multiple feedback configuration, the GBWP of your amplifier should be equal to or greater than  $100 * (-G_{CLI} + 1)f_c$ , where  $G_{CLI}$  is equal to the inverting gain of your closed-loop system.

In addition to paying attention to the bandwidth of your amplifier, the slew rate should be evaluated in order to ensure that your filter does not create signal distortions. The slew rate of an amplifier is determined by internal currents and capacitances. When large signals are sent through the amplifier, the appropriate currents charge these internal capacitors. The speed of this charge is dependent on the value of the amplifier's internal resistances, capacitances and currents. In order to ensure that your active filter does not enter into a slew condition you need to select an amplifier such that the slew rate ( $2\pi V_{OUT-P-P} f_c$ ), where  $V_{OUT-P-P}$  is the expected peak-to-peak output voltage swing below  $f_c$  of your filter.

There are two, second order specifications that affect your filter circuit. These are Input Common Mode Voltage Range ( $V_{CMR}$ ), for the Sallen-Key circuit and Input Bias Current ( $I_b$ ). In the Sallen-Key configuration,  $V_{CMR}$  will limit the range of your input signal. The power supply current may or may not be a critical specification unless you have an application on a power budget.

Another second order specification to consider is the input bias current. This specification describes the amount of current going in or out of the input pins of the amplifier. If you are using the Sallen-Key filter configuration, as shown in Figure 1, the input bias current of the amplifier will conduct through R2.

The voltage drop caused by this error will appear as an input offset voltage and input noise source. But more critical, high input bias currents in the nano or micro ampere range may motivate you to lower your resistors in your circuit. When you do this, you will increase the capacitors in order to meet your filter cutoff frequency requirements. Large capacitors may not be a very good option because of cost, accuracy and size. Also, be aware that this current will increase with temperature.

If you follow these simple guidelines you should find that designing a successful low-pass filter is not that difficult and you can quickly have a working circuit.